



11 INCH AXIAL FANS

12 VDC PART NUMBERS

F-11-12I - INTAKE
F-11-12E - EXHAUST

24 VDC PART NUMBERS

F-11-24I - INTAKE
F-11-24E - EXHAUST

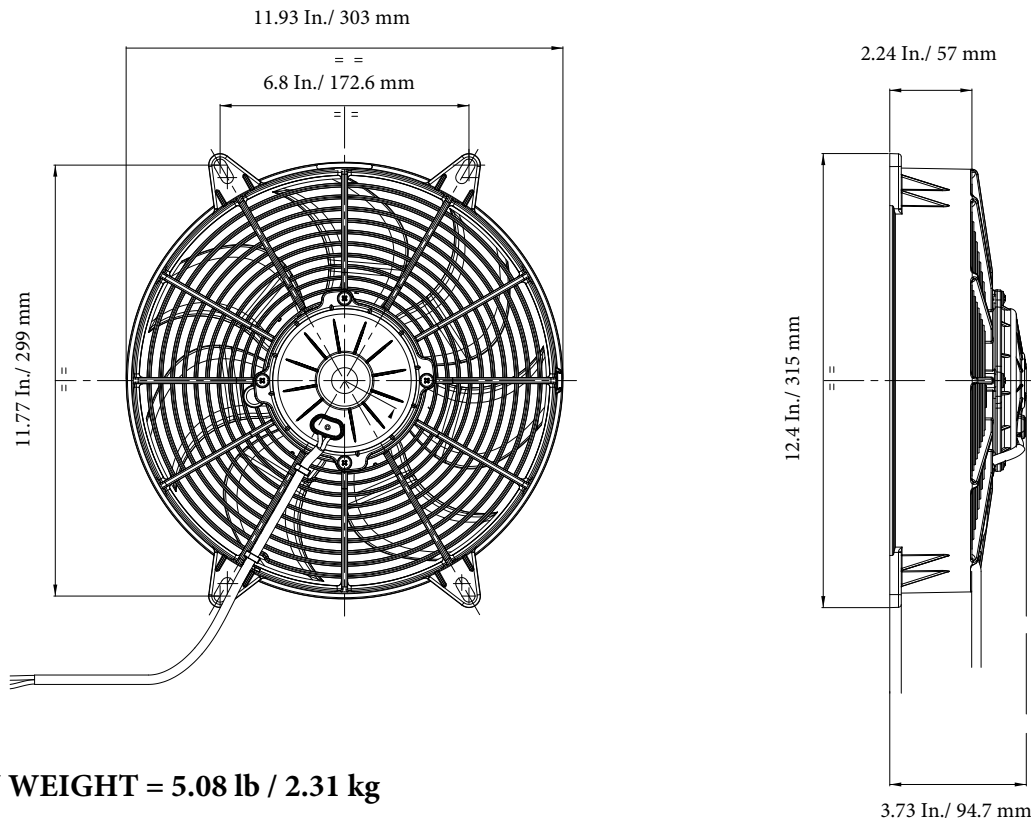

FAN WEIGHT = 5.08 lb / 2.31 kg

Murray Ventilation Products (MVP) DC axial fans are built to operate in the harsh marine environment. Dedicated wheel configurations ensure high efficiency through a range of static pressures, unlike reversible wheel units offered by others.

Motors are IP68 rated, which means they are sealed and can operate submersed in water for extended periods. Fan housings and wheels are made with glass reinforced nylon, making them corrosion free for long life. All hardware and shafting are stainless steel.

MVP fans are built to ISO 9001 and TS16949 standards and have CE equivalency (European conformity).



11 INCH FAN PERFORMANCE CURVES

